

MS® Deadbolt

For Aluminum Stile Doors - 1" x 6-7/8" Faceplate

MS1850S-050 Series

ANSI/BHMA Type E8281/E8291 (Grade 1)

▼ Cylinder Backset

31/32", 1-1/8" or 1-1/2" only.

▼ Case

Steel with corrosion-resistant plating. 1" x 6" x depth. (Depth varies by backset. See table on back page).

▼ Function

The MS® Hookbolt deadlock answers the security need of sliding glass doors in commercial, industrial and institutional buildings. The mechanism is identical to the widely used Maximum Security swinging door lock, except that the massive laminated bolt is provided in a hook shape to resist the parting motion of sliding door and jamb. The overcenter MS® locking action assures that forced entry attempts to pry the door in any direction, up, down or sideways, will be defeated.

▼ Bolt

5/8" x 1-3/8" with 13/16" throw. Eight-ply laminated stainless steel with Alumina Ceramic core defeats any hacksaw attack (including so-called super hacksaws) while hook shape repels prybar attempts to "spread" door from its jamb or lift it off its track.

▼ Strike

See back page for dimensions of strike slot which can be cut in metal jamb. Trim plate, box strike and armored strike are also available. (See page SW-16).

▼ Operation

360° turn of key or thumbturn throws or retracts the counterbalanced bolt. Key can be removed only when bolt is in a positively locked or unlocked position. Lock accepts any standard 1-5/32" diameter mortise cylinder or thumbturn from either or both sides. Cylinder must have MS® dimensioned cam. (See page SW-32).



ADAMS RITE
MANUFACTURING CO.

260 Santa Fe Street
Pomona, California 91767
(800) 872-3267 Fax: (800) 232-7329
www.adamsrite.com

MS1850S-050 Deadbolt

DIMENSIONS

INCHES
MILLIMETERS
Nominal, subject to tolerance extremes.

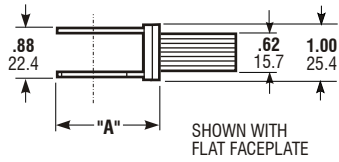

SHOWN WITH FLAT FACEPLATE

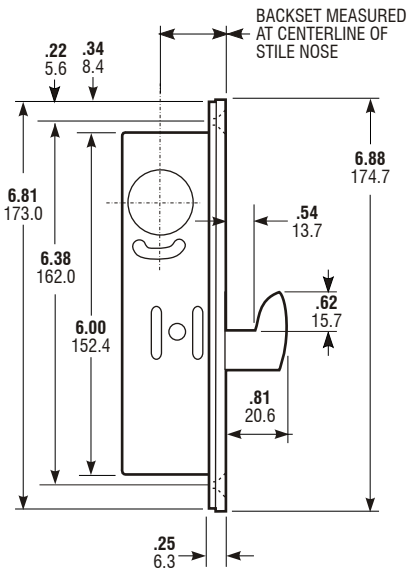

BACKSET MEASURED AT CENTERLINE OF STILE NOSE

| BACKSET | "A" |
|-----------------------|---------------------|
| 7/8" 22.0 | 1.57 39.9 |
| 31/32" 24.6 | 1.63 41.4 |
| 1-1/8" 28.6 | 1.78 45.2 |
| 1-1/2" 38.1 | 2.25 57.1 |

| ARMORED FACEPLATE 1" x 6-7/8" | |
|----------------------------------|--------------|
| FLAT | MS1850S-050 |
| RADIUS | MS1851S-050 |
| RADIUS w/WEATHERSTRIP | MS1851SW-050 |
| LH BEVEL | MS1852S-055 |
| RH BEVEL | MS1852S-056 |

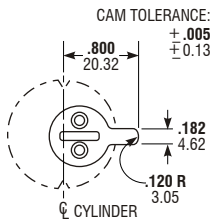

Cylinder Cam

MS1850S-050 Series locks are operable by any standard 1-5/32" diameter mortise cylinder with special MS® cam dimensioned as shown. Cylinders with MS® cams can be readily obtained from most cylinder manufacturers. See page SW-32 for cylinder make and trim ring information.

INSTALLATION

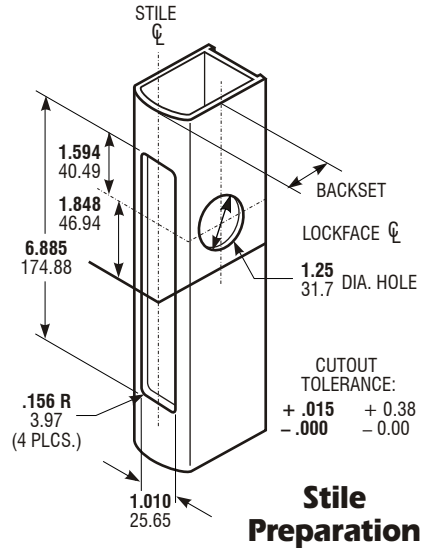
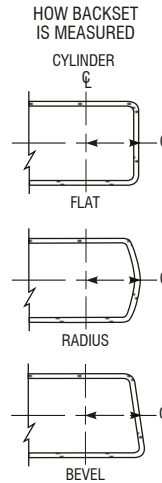

Stile Preparation

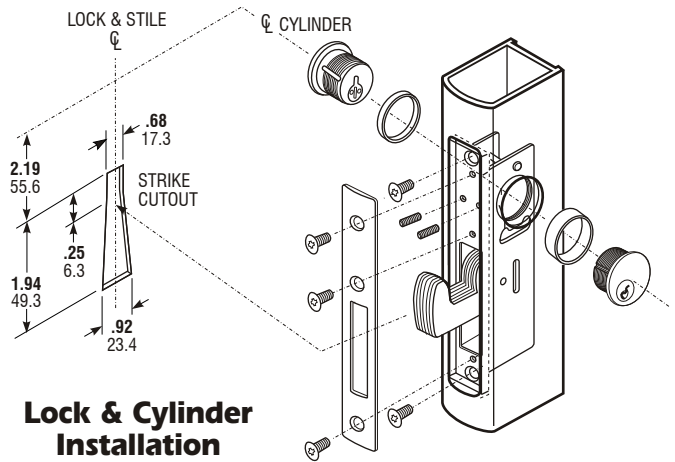

Lock & Cylinder Installation

HOW TO ORDER

Specify quantity and the following information.
Order related hardware separately.

Faceplate Shape

- 1850S** Flat
- 1851S** Radius
- 1851SW** Radius w/w'strip
- 1852S** Bevel

Backset

- 2** 31/32"
- 3** 1-1/8"
- 4** 1-1/2"

Handing

- 55** LH or RHR
- 56** RH or LHR
- 50** Non-Handed*

MS1850S - 250 - 628

Finish

- 628** Clear Anodized
- 313** Dark Bronze Anod.
- 335** Black Anodized

OPTIONS

Cylinder backset and faceplate finish and shape (radiused, flat or bevel cross-section to match door nose) must be specified.

STANDARD PACKAGE

Individually boxed with machine screws for mounting. Cylinders and/or thumbturn available at extra cost. Shipping weight: 1-1/2 lbs. Also available in a 25 unit pack for volume users.

*Any flat or radius face.